

WATERPRESS SUPERINOX
BOOSTER SETS - FIX SPEED

- Pressure tank in stainless steel
- Continuous service
- High hydraulic efficiency
- High-efficiency motors according to EU(2019)/1781



ALL PUMPS DIRECT
FOR ALL YOUR PUMPING SOLUTIONS

UK's No.1 Supplier

www.allpumpsdirect.co.uk



DESCRIPTION

The Pressure booster set WATERPRESS SUPERINOX are made with a JETINOX self-priming centrifugal pump. They are supplied wired and complete with a stainless steel pressure tank.

APPLICATIONS

- Lifting and distribution of water in domestic systems in continuous or intermittent operation
- Pressurization systems
- Washing and irrigation

PERFORMANCE

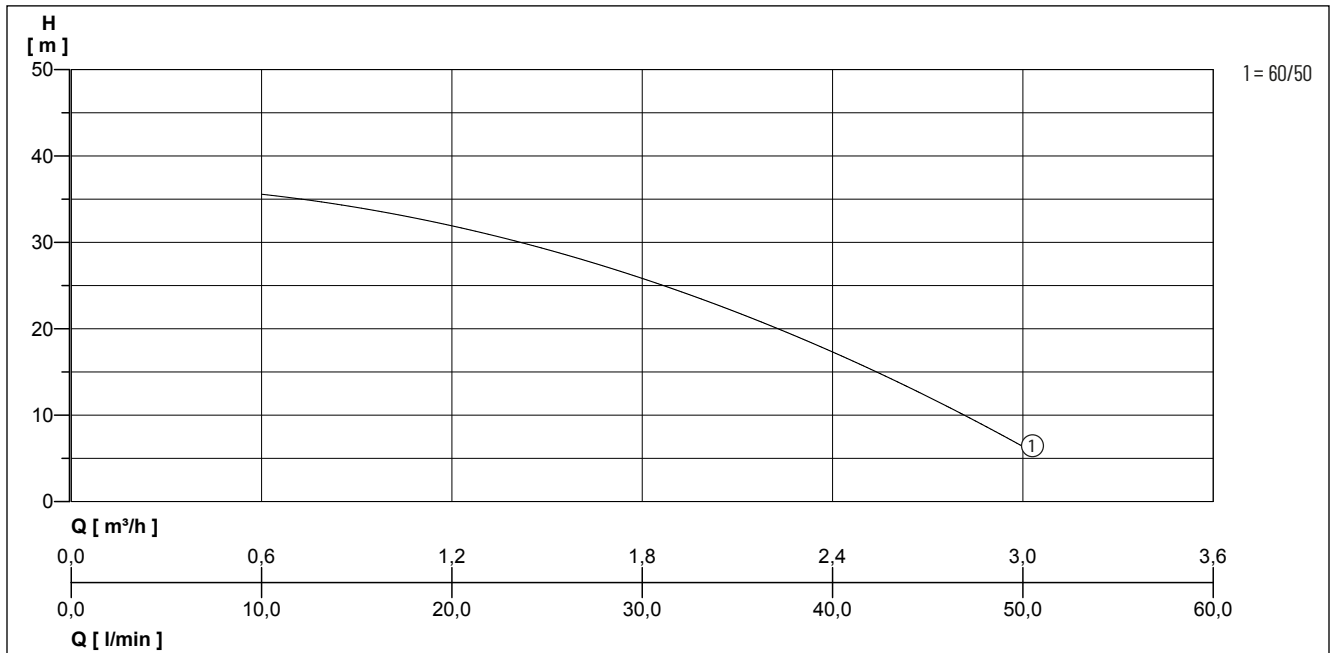

We reserve the right to change specifications without notice. Pump performance is subject to ISO 9906 ISO 9906:2012 - Grade 3B tolerances.

Type	Flow rate Q [m³/h]	0	0.6	1.2	1.8	2.4	3
WATERPRESS-SUPERINOX 60/50-C	Delivery head H [m]	46	36	31	26	18	6

WATERPRESS SUPERINOX

BOOSTER SETS - FIX SPEED

MECHANICAL DATA

Shaft	Stainless steel X 12 CrNiS 1809 (AISI 416)	Counterface	Ceramic
Impeller	Technopolymer with stainless steel shim ring	Operating pressure max.	6 bar
Motor housing	Die-cast aluminium	Type of liquid	clean water without suspended solids or abrasive material
Pump housing	Stainless steel X5 CrNi 1810 (AISI 304)	Temperature of the liquid max.	50 °C
Diffuser	Technopolymer	Suction height max	8 m
Mechanical seal	Graphite	Gasket	NBR 70 shore
		Weight	11.2 kg

ELECTRICAL DATA

Voltage	1/N/PE~230 V	Power line	1.5 m H05 RN-F
Motor rating P1	0.72 kW	Type of enclosure	IP 44
Motor rating P2	0.45 kW	Insulation class	F
Current	3.2 A	Plug	Safety

WATERPRESS SUPERINOX

Type	Code No.
WATERPRESS-SUPERINOX 60/50-C	N5209682

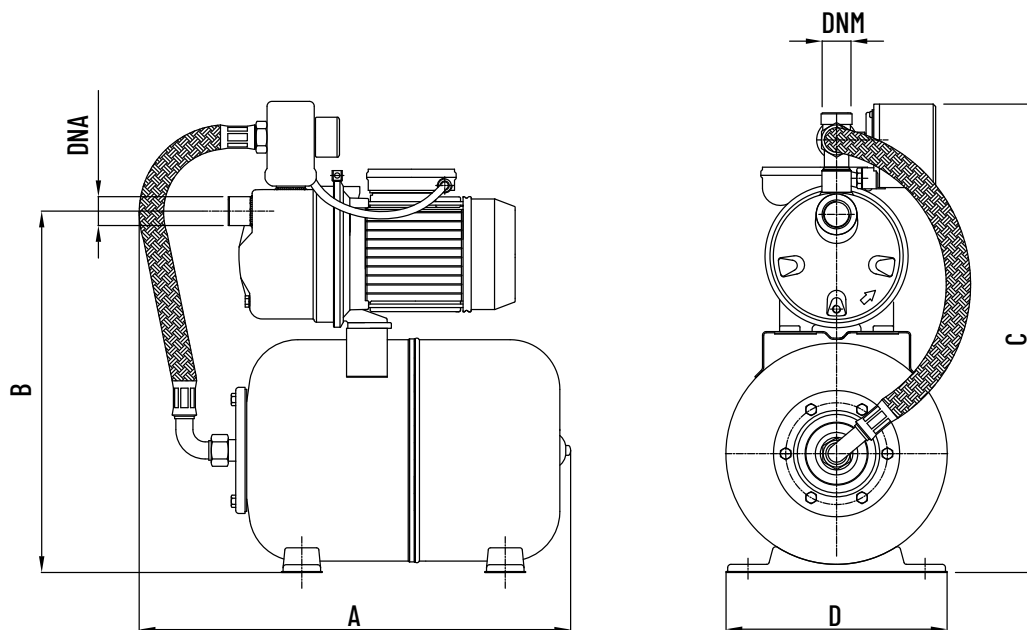

DIMENSIONS [mm]

Type	A	B	C	D	DNA	DNM
WATERPRESS-SUPERINOX 60/50-C	530	425	550	272	1" F	1" F