

WP/MULTI EVO-A
BOOSTER SETS - FIX SPEED



- Reduces water hammer effect
- Ideal as a water supply system in the building
- Ready to use
- Reduction of the starting frequency with the 50 l tank
- Very easy to install
- High-efficiency motors according to EU(2019)/1781



DESCRIPTION

The Pressure booster set WATERPRESS are made with self-priming multi-stage centrifugal pumps Multi EVO-A. They are supplied wired, complete with a 24 l or 50 l expansion module, ready for installation and use. All models are certified for use with drinking water (ACS).

APPLICATIONS

- Lifting and distribution of water in domestic systems in continuous or intermittent operation
- Pressurization systems
- Washing systems
- Irrigation

PERFORMANCE

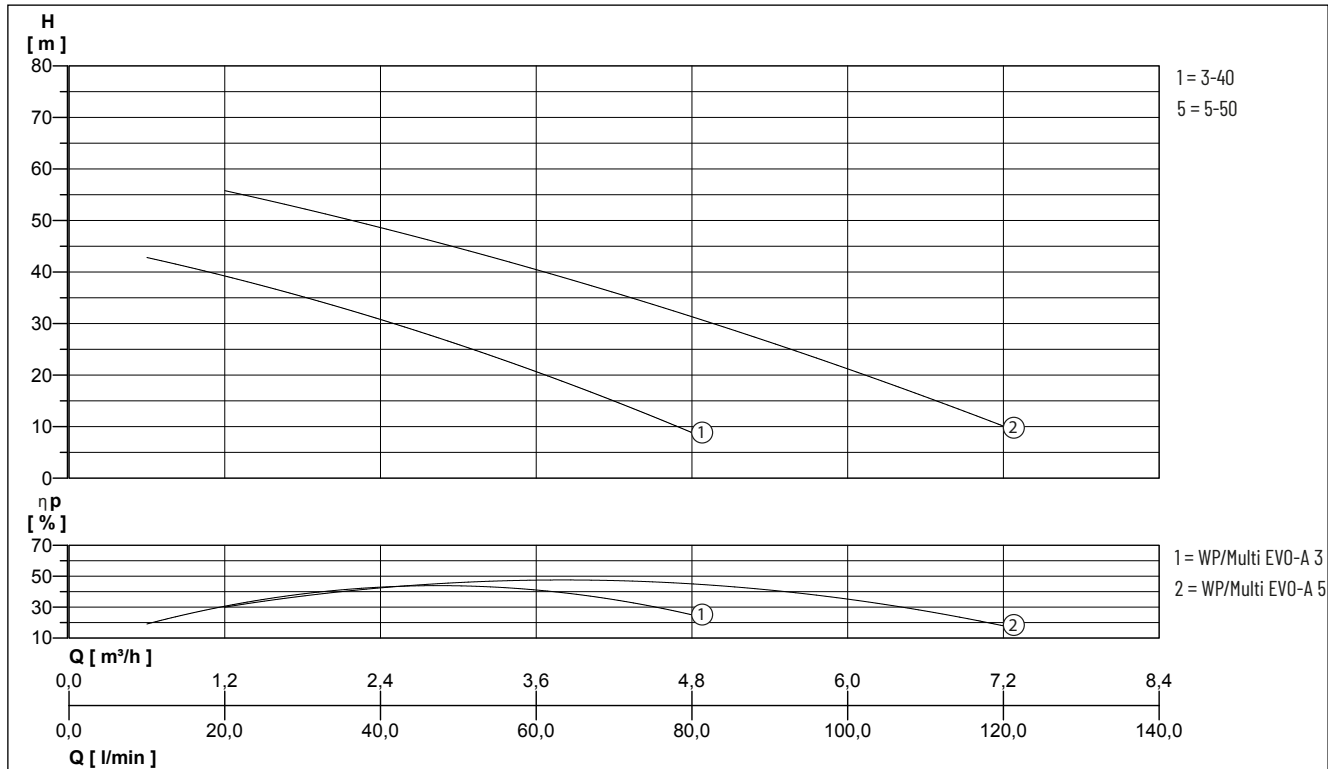

We reserve the right to change specifications without notice. Pump performance is subject to ISO 9906 ISO 9906:2012 - Grade 3B tolerances.

Type	Flow rate Q [m³/h]	0.6	1.2	1.8	2.4	3	3.6	4.8	6	7.2
WP/Multi EVO-A 3-40 M/M-50I 230V-50Hz	Delivery head H [m]	42.5	39.5	35.5	31.0	25.5	20.5	9.0		
WP/Multi EVO-A 5-50 M-SS/M-50I 230V-50Hz			56.0	52.0	48.5	45.0	40.5	31.0	21.5	10.0

WP/MULTI EVO-A

BOOSTER SETS - FIX SPEED

MECHANICAL DATA

Shaft	Stainless steel X5 CrNi 1810 (AISI 304)	Counterface	Ceramic / NBR
Impeller	PPO reinforced with fibreglass	Operating pressure max.	8 bar
Motor housing	Die-cast aluminium	Type of liquid	clean water without suspended solids or abrasive material
Pump housing	Stainless steel X5 CrNi 1810 (AISI 304)	Temperature of the liquid max.	50 °C
Diffuser	PPO reinforced with fibreglass	Suction height max	8 m
Mechanical seal	Carbon graphite / NBR / SS	Gasket	NBR 70 Shore A

ELECTRICAL DATA

Voltage	1/N/PE~230 V	Insulation class	F
Power line	1.5 m H05 RN-F	Plug	Safety
Type of enclosure	IP 55		

WP/MULTI EVO-A

Type	Code No.	Motor rating		Current	Rotation speed	Weight
		P1	P2			
WP/Multi EVO-A 3-40 M 230V-50Hz	N5302540	0.75 kW	0.40 kW	3.4 A	-	13.6 kg
WP/Multi EVO-A 3-40 M-50I 230V-50Hz	N5302542	0.75 kW	0.40 kW	3.4 A	2800 rpm	18.0 kg
WP/Multi EVO-A 5-50 M-SS 230V-50Hz	N5304551	1.30 kW	0.75 kW	6.0 A	-	14.0 kg
WP/Multi EVO-A 5-50 M-50I 230V-50Hz	N5304552	1.30 kW	0.75 kW	6.0 A	-	20.5 kg

241

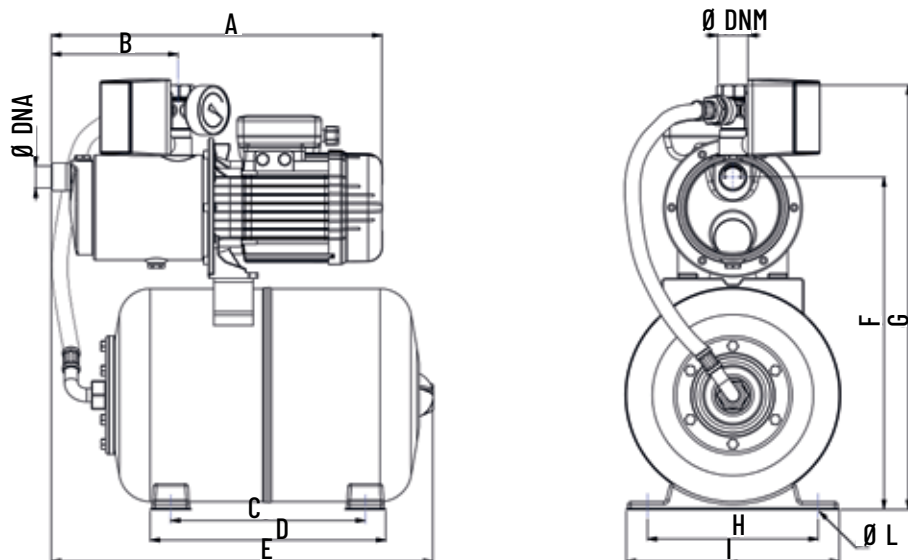

WP/MULTI EVO-A

BOOSTER SETS - FIX SPEED

50 l

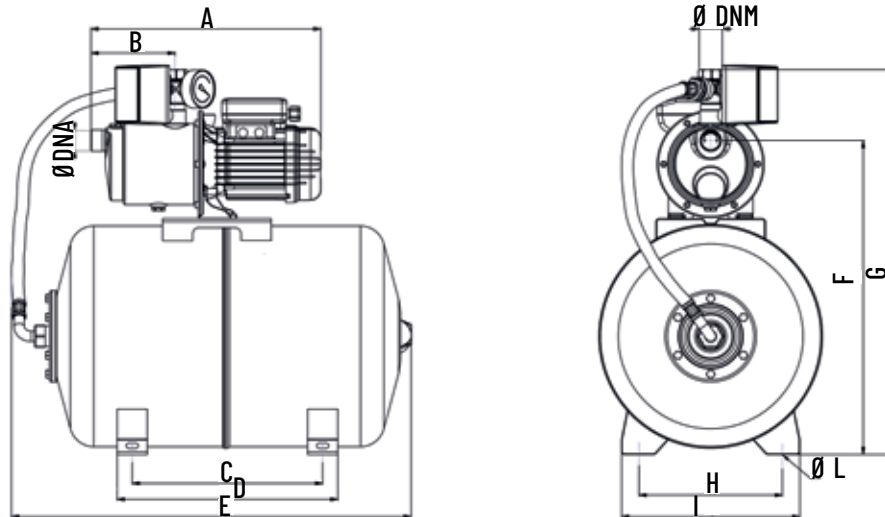

DIMENSIONS [mm]

Type	A	B	C	D	F	G	H	I	L	DNA	DNM	E
WP/Multi EVO-A 3-40 M 230V-50Hz	380	139	245	295	410	530	190	240	9	1"	1"	495
WP/Multi EVO-A 3-40 M-50l 230V-50Hz	380	139	315	365	520	640	242	295	9	1"	1"	660
WP/Multi EVO-A 5-50 M-SS 230V-50Hz	422	162	248	300	435	540	218	272	11	1"	1"	490
WP/Multi EVO-A 5-50 M-50l 230V-50Hz	422	162	215	365	520	640	242	295	9	1"	1"	660

WP/MULTI EVO-A

BOOSTER SETS - FIX SPEED