

MULTINOX-VE+

SURFACE PUMPS - VERTICAL MULTISTAGE



- High hydraulic efficiency
- Strong and resistant
- Motor designed according to EN regulations
- Many possible uses for the residential market
- High-efficiency motors according to EU(2019)/1781

ALL PUMPS DIRECT
FOR ALL YOUR PUMPING SOLUTIONS

UK's No.1 Supplier

www.allpumpsdirect.co.uk



DESCRIPTION

The MULTINOX-VE+ series vertical multi-stage centrifugal pumps are particularly suitable for the realization of lifting units, especially in the cases where high efficiency and silence are required, with compact dimensions.

APPLICATIONS

- Lifting and distribution of water in domestic systems in continuous or intermittent operation
- Pressurization systems
- Fire protection systems
- Washing, garden irrigation, supply to fountains, transfers.

PERFORMANCE

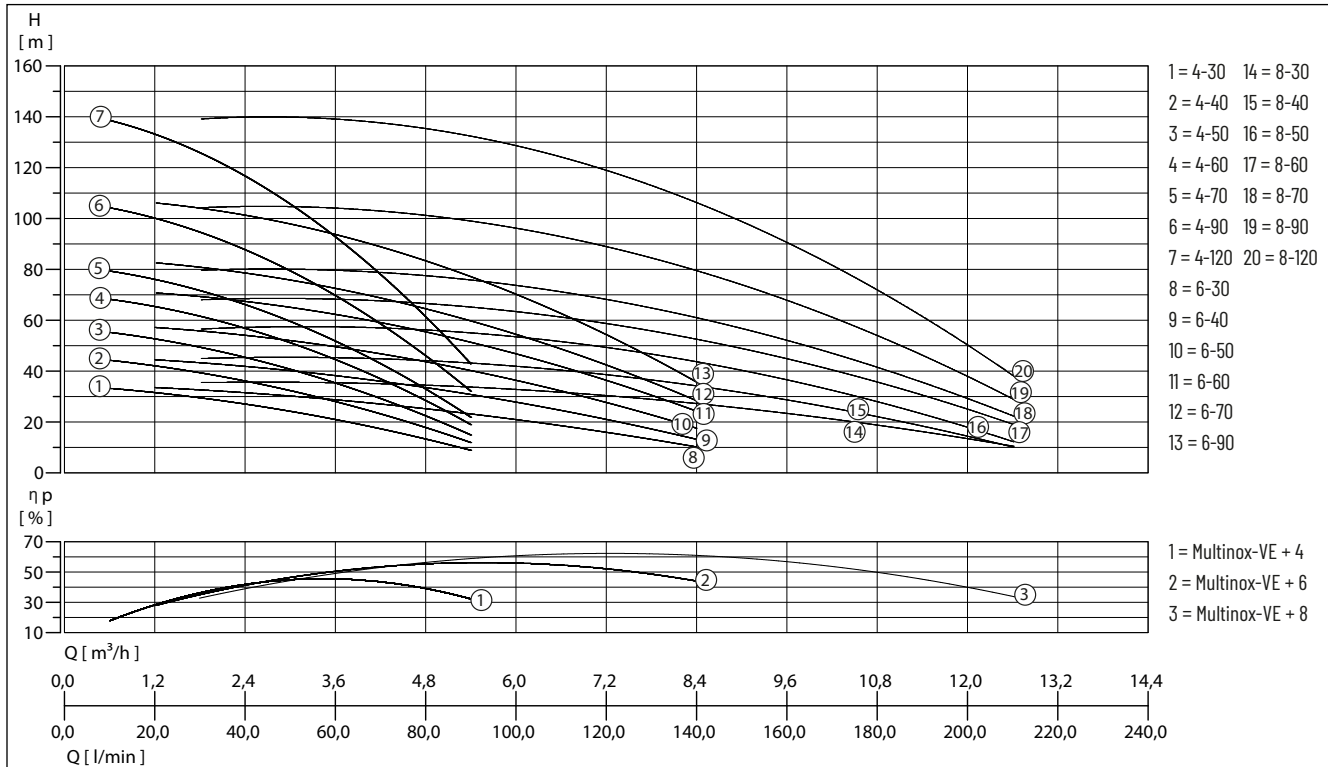

We reserve the right to change specifications without notice. Pump performance is subject to ISO 9906 ISO 9906:2012 - Grade 3B tolerances. MEI ≥ 0.4 - Reference MEI ≥ 0.70 - The information on the reference efficiency is available at the address: www.europump.org/efficiencycharts

MULTINOX-VE+

SURFACE PUMPS - VERTICAL MULTISTAGE

Type	Flow rate Q [m ³ /h]	0.6	1.2	1.8	2.4	3	3.6	4.2	4.8	5.4	6	7.2	8.4	9	10.8	12.6
MULTINOX VE+ 4-30 M/T	Delivery head H [m]	33		30	27	24	21	17		9						
MULTINOX VE+ 4-40 M/T		44		40	36	32	28	23		12						
MULTINOX VE+ 4-50 M/T		55		50	45	41	35	29		15						
MULTINOX VE+ 4-60 M/T		68		62	57	51	44	37		19						
MULTINOX VE+ 4-70 M/T		79		72	67	59	51	43		22						
MULTINOX VE+ 4-90 T		104		95	88	79	69	59		32						
MULTINOX VE+ 4-120 T		138		127	117	105	92	78		43						
MULTINOX VE+ 6-30 M/T			34		31		28		26		21	16	10			
MULTINOX VE+ 6-40 M/T			45		41		38		34		28	21	13			
MULTINOX VE+ 6-50 M/T			58		53		49		44		37	28	17			
MULTINOX VE+ 6-60 M/T			71		66		61		55		47	36	23			
MULTINOX VE+ 6-70 T			83		77		71		64		55	42	27			
MULTINOX VE+ 6-90 T			107		99		92		83		71	54	34			
MULTINOX VE+ 8-30 M/T				35			35			33		30		25	18	10
MULTINOX VE+ 8-40 M/T				45			44			42		39		32	20	11
MULTINOX VE+ 8-50 M/T				57			56			53		50		40	28	16
MULTINOX VE+ 8-60 T				68			67			64		60		48	34	19
MULTINOX VE+ 8-70 T				80			78			74		70		56	40	22
MULTINOX VE+ 8-90 T				104			103			98		90		73	52	29
MULTINOX VE+ 8-120 T				139			138			131		120		98	70	38

MECHANICAL DATA

Shaft	Stainless steel X5 CrNi 1810 (AISI 304)	Type of liquid	clean water without suspended solids or abrasive material
Impeller	Technopolymer	Temperature of the liquid max.	50 °C
Pump housing	Stainless steel X5 CrNi 1810 (AISI 304)	Suction height max	6 m
Diffuser	Technopolymer	Gasket	NBR

ELECTRICAL DATA

Insulation class	F	Rotation speed	-
Ambient temperature max.	40 °C		

MULTINOX-VE+

SURFACE PUMPS - VERTICAL MULTISTAGE

MULTINOX-VE+

Type	Code No.	Voltage	Motor rating		Current	Type of enclosure	Operating pressure max.	Weight
			P1	P2				
Mechanical seal:, Counterface:								
MULTINOX VE+ 4-30 M	N10G02030	1/N/PE~230 V	0.85 kW	0.9 kW	3.3 A	IP 44	9 bar	19 kg
MULTINOX VE+ 4-30 T	N10G12030	3/PE~230/400 V	0.73 kW	0.7 kW	2.6 A/1.5 A	IP 44	9 bar	19 kg
MULTINOX VE+ 4-40 M	N10G02040	1/N/PE~230 V	0.98 kW	0.9 kW	4.0 A	IP 44	9 bar	21 kg
MULTINOX VE+ 4-40 T	N10G12040	3/PE~230/400 V	0.91 kW	0.7 kW	3.1 A/1.8 A	IP 44	9 bar	21 kg
MULTINOX VE+ 4-50 M	N10G02050	1/N/PE~230 V	1.20 kW	0.9 kW	5.0 A	IP 44	9 bar	23 kg
MULTINOX VE+ 4-50 T	N10G13050	3/PE~230/400 V	1.10 kW	1.3 kW	3.9 A/2.2 A	IP 44	9 bar	23 kg
MULTINOX VE+ 4-60 M	N10G02060	1/N/PE~230 V	1.50 kW	1.3 kW	6.7 A	IP 44	9 bar	25 kg
MULTINOX VE+ 4-60 T	N10G13060	3/PE~230/400 V	1.30 kW	1.3 kW	4.2 A/2.4 A	IP 44	9 bar	25 kg
MULTINOX VE+ 4-70 M	N10G02070	1/N/PE~230 V	1.70 kW	1.3 kW	7.2 A	IP 44	9 bar	27 kg
MULTINOX VE+ 4-70 T	N10G13070	3/PE~230/400 V	1.50 kW	1.3 kW	4.7 A/2.7 A	IP 44	9 bar	27 kg
MULTINOX VE+ 4-90 T	N10G13090	3/PE~230/400 V	1.78 kW	1.5 kW	5.7 A/3.4 A	IP 44	12 bar	28 kg
MULTINOX VE+ 4-120 T	N10G13120	3/PE~230/400 V	2.30 kW	1.5 kW	7.4 A/4.2 A	IP 44	16 bar	30 kg
MULTINOX VE+ 6-30 M	N11G02030	1/N/PE~230 V	0.98 kW	0.9 kW	4.0 A	IP 44	9 bar	19 kg
MULTINOX VE+ 6-30 T	N11G12030	3/PE~230/400 V	0.91 kW	0.7 kW	3.1 A/1.8 A	IP 44	9 bar	19 kg
MULTINOX VE+ 6-40 M	N11G02040	1/N/PE~230 V	1.35 kW	1.3 kW	6.0 A	IP 44	9 bar	21 kg
MULTINOX VE+ 6-40 T	N11G13040	3/PE~230/400 V	1.10 kW	1.3 kW	3.9 A/2.2 A	IP 44	9 bar	21 kg
MULTINOX VE+ 6-50 M	N11G02050	1/N/PE~230 V	1.50 kW	1.3 kW	6.7 A	IP 44	9 bar	23 kg
MULTINOX VE+ 6-50 T	N11G13050	3/PE~230/400 V	1.30 kW	1.3 kW	4.2 A/2.4 A	IP 44	9 bar	23 kg
MULTINOX VE+ 6-60 M	N11G02060	1/N/PE~230 V	1.75 kW	1.3 kW	7.4 A	IP 44	9 bar	25 kg
MULTINOX VE+ 6-60 T	N11G13060	3/PE~230/400 V	1.55 kW	1.3 kW	4.9 A/2.8 A	IP 44	9 bar	25 kg
MULTINOX VE+ 6-70 T	N11G13070	3/PE~230/400 V	1.70 kW	1.5 kW	5.6 A/3.3 A	IP 44	9 bar	27 kg
MULTINOX VE+ 6-90 T	N11G13090	3/PE~230/400 V	2.10 kW	1.5 kW	7.1 A/4.0 A	IP 44	12 bar	28 kg
MULTINOX VE+ 8-30 M	N9G02030	1/N/PE~230 V	1.40 kW	0.9 kW	6.0 A	IP 44	9 bar	19 kg
MULTINOX VE+ 8-30 T	N9G13030	3/PE~230/400 V	1.20 kW	1.3 kW	4.0 A/2.3 A	IP 44	9 bar	19 kg
MULTINOX VE+ 8-40 M	N9G02040	1/N/PE~230 V	1.75 kW	1.3 kW	7.5 A	IP 44	9 bar	21 kg
MULTINOX VE+ 8-40 T	N9G13040	3/PE~230/400 V	1.55 kW	1.3 kW	4.9 A/2.8 A	IP 44	9 bar	21 kg
MULTINOX VE+ 8-50 M	N9G02050	1/N/PE~230 V	2.00 kW	1.3 kW	8.6 A	IP 44	9 bar	23 kg
MULTINOX VE+ 8-50 T	N9G13050	3/PE~230/400 V	1.80 kW	1.5 kW	5.7 A/3.3 A	IP 44	9 bar	23 kg
MULTINOX VE+ 8-60 T	N9G13060	3/PE~230/400 V	2.10 kW	1.5 kW	6.6 A/3.8 A	IP 44	9 bar	25 kg
MULTINOX VE+ 8-70 T	N9G13070	3/PE~230/400 V	2.30 kW	1.5 kW	7.4 A/4.2 A	IP 44	9 bar	27 kg
Mechanical seal:Graphite/Silicon Carbide , Counterface:Aluminium Oxide / Graphite								
MULTINOX VE+ 8-90 T	N9G11090	3/PE~230/400 V	3.20 kW	3.0 kW	10.2 A/5.9 A	IP 55	20 bar	36 kg
MULTINOX VE+ 8-120 T	N9G11120	3/PE~230/400 V	4.60 kW	4.0 kW	13.5 A/7.6 A	IP 55	20 bar	39 kg

MULTINOX-VE+

SURFACE PUMPS - VERTICAL MULTISTAGE

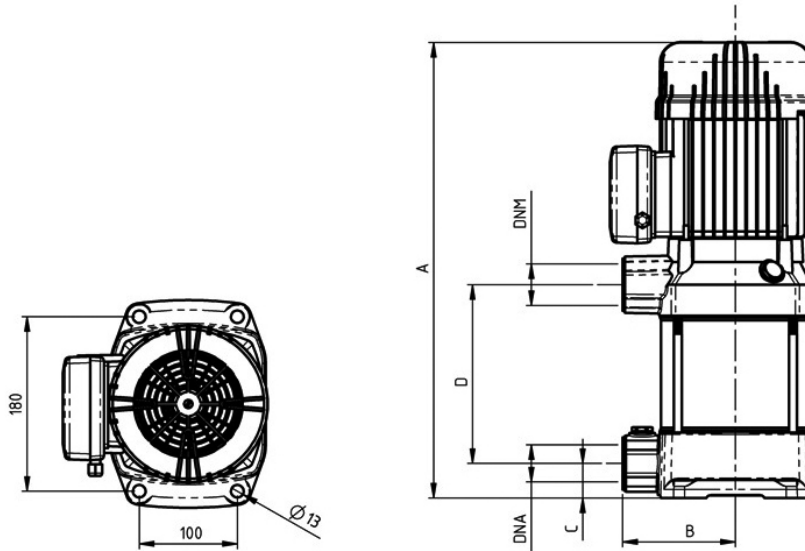

DIMENSIONS [mm]

Type	A	B	C	D	DNA	DNM
MULTINOX VE+ 4-30 M/T	416	115	35	130	1 1/4"	1 1/4"
MULTINOX VE+ 4-40 M/T	443	115	35	157	1 1/4"	1 1/4"
MULTINOX VE+ 4-50 M/T	470	115	35	184	1 1/4"	1 1/4"
MULTINOX VE+ 4-60 M/T	497	115	35	211	1 1/4"	1 1/4"
MULTINOX VE+ 4-70 M/T	524	115	35	238	1 1/4"	1 1/4"
MULTINOX VE+ 4-90 T	578	115	35	292	1 1/4"	1 1/4"
MULTINOX VE+ 4-120 T	660	115	35	373	1 1/4"	1 1/4"
MULTINOX VE+ 6-30 M/T	416	115	35	130	1 1/4"	1 1/4"
MULTINOX VE+ 6-40 M/T	443	115	35	157	1 1/4"	1 1/4"
MULTINOX VE+ 6-50 M/T	470	115	35	184	1 1/4"	1 1/4"
MULTINOX VE+ 6-60 M/T	497	115	35	211	1 1/4"	1 1/4"
MULTINOX VE+ 6-70 T	524	115	35	238	1 1/4"	1 1/4"
MULTINOX VE+ 6-90 T	578	115	35	292	1 1/4"	1 1/4"
MULTINOX VE+ 8-30 M/T	416	115	35	130	1 1/4"	1 1/4"
MULTINOX VE+ 8-40 M/T	443	115	35	157	1 1/4"	1 1/4"
MULTINOX VE+ 8-50 M/T	470	115	35	184	1 1/4"	1 1/4"
MULTINOX VE+ 8-60 T	497	115	35	211	1 1/4"	1 1/4"
MULTINOX VE+ 8-70 T	524	115	35	238	1 1/4"	1 1/4"
MULTINOX VE+ 8-90 T	730	115	35	292	1 1/4"	1 1/4"
MULTINOX VE+ 8-120 T	855	115	35	373	1 1/4"	1 1/4"