

Installation, Operation, Repair and Parts Manual

Description

SPECIFICATIONS

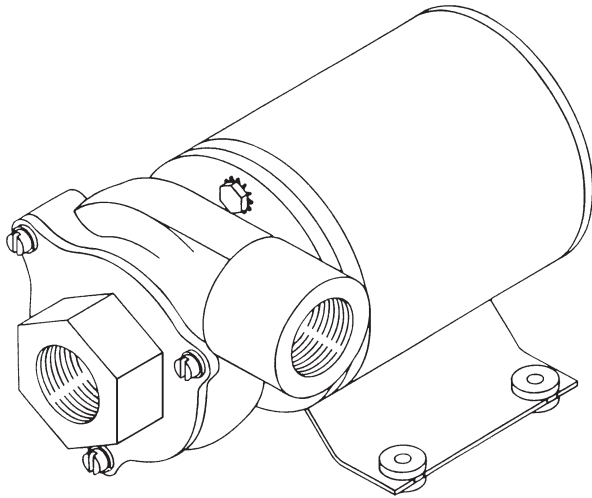

Body/Impeller: 9700B - Bronze/ 9700S - Stainless Steel
Seal:9700B: Lip-type Viton* / 9700S: Mechanical
Port Size: 3/4" NPT (F)
Max. Temperature: 140° F
Max. PSI: 7.0 psi
Max. Current: 5.0 Amps
Weight: 5 lbs. (2.3 kg) approx.
Motor: Stainless steel shaft, permanent magnet, fully enclosed, ignition protected

⚠ California Proposition 65 Warning -- This product and related accessories contain chemicals known to the State of California to cause cancer, birth defects or other reproductive harm.

APPLICATION

The Aqua-Tiger is suitable for general pumping applications where a flooded intake is provided. Typical applications include livewell filling and circulation and any other application not requiring a self-priming pump.

Performance Chart

Model 9700 Aqua-Tiger			
VOLTS	PSI	AMPS	GPM
13.5 (Alternator) Engine Running	1	5.5	19.0
	2	5.3	16.5
	3	5.0	14.0
	4	4.9	12.5
	5	4.5	10.0
	6	4.1	6.5
	7	3.7	2.7

General Safety Information

- 1. WARNING: DO NOT pump solvents, thinners or gasoline, as explosion may result causing personal injury or death and/or property damage. DO NOT use in explosive atmospheres. The pump should be used only with liquids compatible with the pump component materials. Failure to follow this warning will void the product warranty.**
- 2. WARNING: DO NOT operate with any of the mounting bolts removed from the motor case. Explosion resulting in personal injury, death or property damage may occur. Case openings must be sealed to avoid explosion and maintain ignition protected rating.**
3. Do not pump liquids at temperatures higher than the recommended maximum temperatures (140° F).
4. Disconnect power before servicing.
5. Drain all liquids from the system before servicing any component.
6. Check hose for weak or worn condition before each use. Make certain that all connections are tight and secure.
7. Periodically inspect the pump and the system components. Perform routine maintenance as required (see Maintenance section).
8. Do not use these pumps for pumping water or other liquids for human or animal consumption.

Hazardous Substance Safety Information

1. Always drain and flush the pump before servicing or disassembling for any reason (see instructions).
2. Always drain and flush pumps prior to returning unit for repair.
3. Never store pumps containing hazardous chemicals.
4. Before returning the pump for service/repair, drain out all liquids and flush the unit with neutralizing liquid. Then, drain the pump. Attach a tag or include a written notice certifying that this has been done. Please note that it is illegal to ship or transport any hazardous chemicals without United States Environmental Protection Agency Licensing.

Installation and Operation

The pump must be mounted in a dry location. The motor is not waterproof; therefore, it must not be submerged. The unit can be operated in any position. It is advantageous to mount the pumps so the water dripping from a loose port connection will not wet the motor. The pump head may be mounted at 90° increments on the motor to allow mounting as needed.

OPERATION

Try not to run the pump dry because doing so shortens the seal life. If you must run the pump dry, do so only for short periods of time. The pump may run against a closed outlet. Small particles will pass through the pump, so a 50-mesh intake strainer should be fitted to the pump.

CAUTION: The motor runs hot, up to 180° F on the motor case. Contact during operation may cause a burn.

ELECTRICAL HOOKUP

WARNING: If the pump is operated in an area containing flammable vapors, wire leads must be joined by insulated mechanical locking connectors. Loose or inadequate wire connections can spark resulting in explosion. Property damage, injury or death may occur.

CAUTION: Lead wires on the motor must not be shortened or the warranty will be voided.

Positive terminal of the battery is connected to an overload protected distribution panel. The red lead with the fuse holder is connected to the distribution panel. The black wire is connected to the negative terminal of the battery. For proper operation, the motor must rotate clockwise when viewed from the pump end. The proper sized fuse has been installed in the fuse holder. If this fuse blows, replace it with the same size fuse after determining the reason for the blown fuse. Use the proper wire size as determined by the wiring table.

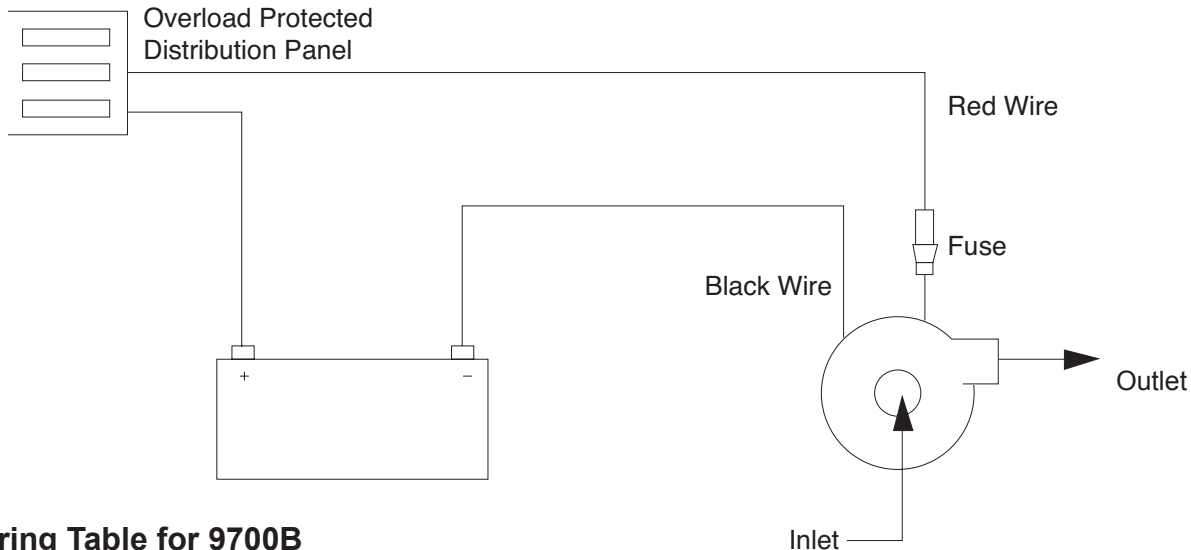

Wiring Table for 9700B

Connection length between battery and motor	Wire Gage
1-10 ft.	#12
11-20 ft.	#10
12-30 ft.	#8

Fuse Sizes for 9700B

Approximate Amp Draw.....	8
Fuse Size.....	10

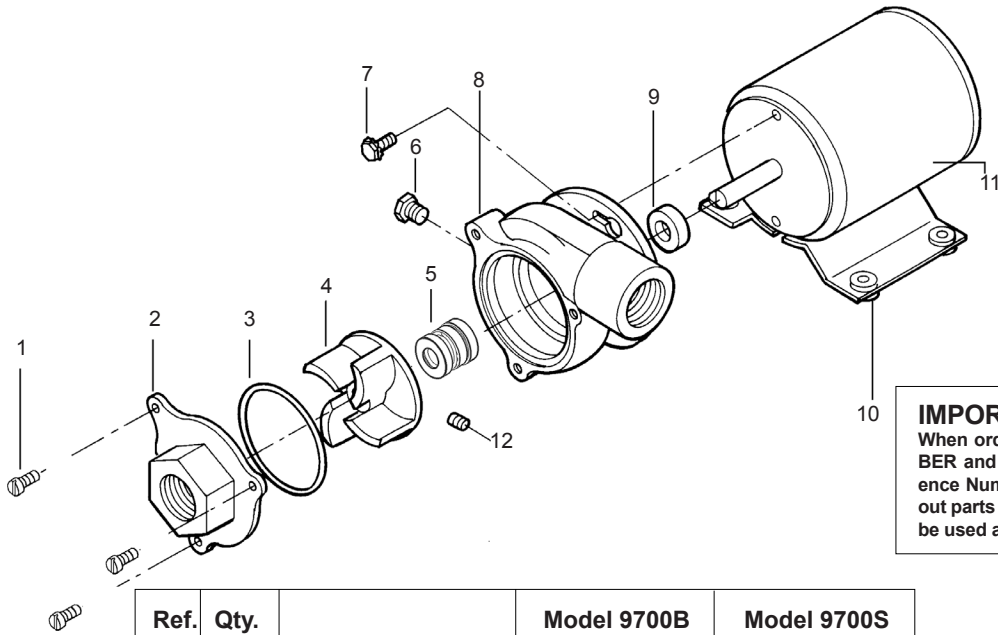

IMPORTANT:
When ordering parts, give PART NUMBER and PART DESCRIPTION. Reference Numbers are used ONLY to point out parts in the drawing and are NOT to be used as ordering numbers.

Ref. No.	Qty. Req'd.	Description	Model 9700B Part Number	Model 9700S Part Number
1	3	Cover Screw	2210-0124	2210-0124
2	1	Cover	19893	23660
3	1	O-ring, Viton*	19898	19898
4	1	Impeller	19892	23659
5	1	Mechanical Seal Assy.**	N/A	23665S
6	1	Pipe Plug	00336	21059
7	2	Hex Head Screw	2210-0123	2210-0123
8	1	Housing	19891	23627
9	1	Lip Seal, Viton*	19928	A/N
10	4	Grommet	21138	21138
11	1	Motor 12VDC (TENV)	23697S	23697S
12	1	Set Screw	19929	19929

TENV = Totally-Enclosed Non-Ventilated

(**) Mechanical seals have carbon ceramic wearing faces and 316 Stainless Steel spring components with Viton elastomers. Manufacturer reserves the right to change parts without notification.

*Viton is a trademark of E.I. Dupont deNemour and Company

Maintenance

MAINTENANCE

Check all electrical and plumbing connections periodically. In salt water applications, corrosion of the electrical connections can cause a loss of performance or non-operation. The motor should be protected with a corrosion inhibiting spray. Any rust should be removed and the motor repainted.

DISASSEMBLY

1. Remove the cover screws, cover and o-ring.
2. Remove the pipe plug on the side of the housing and rotate the impeller so the set screw aligns with the plug hole. Insert a 3/32" allen wrench through the plug hole and loosen the impeller set screw. Remove the impeller.
3. Remove the screws that secure the housing to the motor, and remove the housing.
4. From the inside of the housing, insert a dowel into the seal area and press the seal out of the seal bore.

ASSEMBLY

1. From the rear of the housing, press the seal into the seal bore with the open lip toward the pump cavity.
2. Apply a small amount of grease to the motor shaft in the area where the seal contacts it. Slide the housing onto the shaft and secure it to the motor with the (2) two hex head screws.
3. Align the impeller set screw with the flat on the motor shaft and slide the impeller onto the shaft until it contacts the rear of the housing. Slide the impeller forward 1/32"-1/16" and secure it with the set screw. Rotate the impeller by hand to ensure that it does not rub on the housing. Reinstall the pump plug in the housing.
4. Clean the surfaces of the cover and housing where they make contact. A small amount of grease on the o-ring will ease installation. Place the o-ring on the cover. Align the cover with the housing and secure it with the (3) three cover screws.

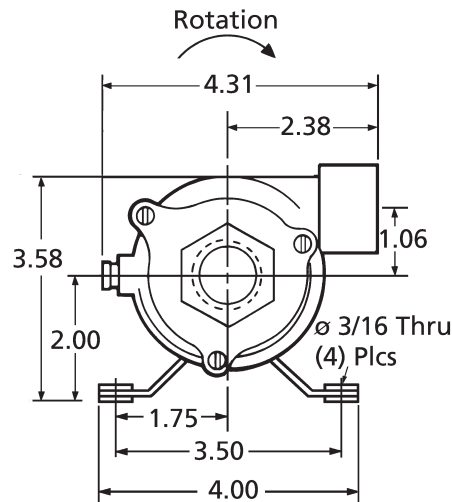
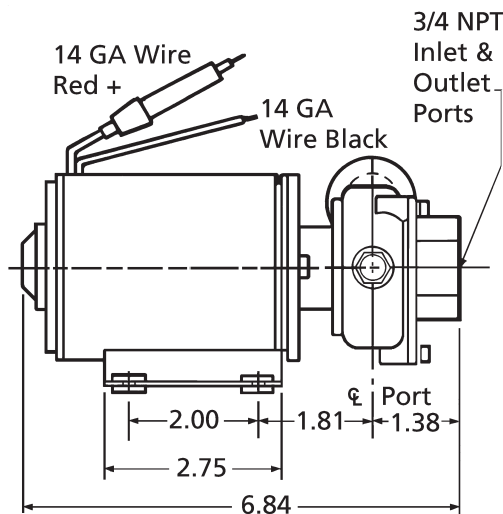

Dimensions are in inches.

Care of the Pump

AFTER USE PUMP CARE

- A. GUMMING — Gumming or corrosion inside the pump can be prevented by thoroughly flushing the pump clean with water or a liquid that will neutralize the liquid pumped. (For many liquids, a solution of 1 gallon ammonia mixed with 6 gallons of water works well.)
- B. To PREVENT RUST/CORROSION, we recommend (after Step A) flushing the pump with permanent-type

automobile radiator antifreeze containing a rust inhibitor, and then preventing air from getting in the pump. Use a 50-50 solution of antifreeze and water. Flush it through the pump, and then drain it. Plug the ports to keep air from getting into the pump during storage. Cleaning and rust protection should be done when the pump will be stored away for more than two to three days.

Limited Warranty on Hypro/SHURflo Agricultural Pumps & Accessories

Hypro/SHURflo (hereafter, "Hypro") agricultural products are warranted to be free of defects in material and workmanship under normal use for the time periods listed below, with proof of purchase.

- Pumps: one (1) year from the date of manufacture, or one (1) year of use. This limited warranty will not exceed two (2) years, in any event.
- Accessories: ninety (90) days of use.

This limited warranty will not apply to products that were improperly installed, misapplied, damaged, altered, or incompatible with fluids or components not manufactured by Hypro. All warranty considerations are governed by Hypro's written return policy.

Hypro's obligation under this limited warranty policy is limited to the repair or replacement of the product. All returns will be tested per Hypro's factory criteria. Products found not defective (under the terms of this limited warranty) are subject to charges paid by the returnee for the testing and packaging of "tested good" non-warranty returns.

No credit or labor allowances will be given for products returned as defective. Warranty replacement will be shipped on a freight allowed basis. Hypro reserves the right to choose the method of transportation.

This limited warranty is in lieu of all other warranties, expressed or implied, and no other person is authorized to give any other warranty or assume obligation or liability on Hypro's behalf. Hypro shall not be liable for any labor, damage or other expense, nor shall Hypro be liable for any indirect, incidental or consequential damages of any kind incurred by the reason of the use or sale of any defective product. This limited warranty covers agricultural products distributed within the United States of America. Other world market areas should consult with the actual distributor for any deviation from this document.

Return Procedures

All products must be flushed of any chemical (ref. OSHA section 1910.1200 (d) (e) (f) (g) (h)) and hazardous chemicals must be labeled/tagged before being shipped* to Hypro for service or warranty consideration. Hypro reserves the right to request a Material Safety Data Sheet from the returnee for any pump/product it deems necessary. Hypro reserves the right to "disposition as scrap" products returned which contain unknown fluids. Hypro reserves the right to charge the returnee for any and all costs incurred for chemical testing, and proper disposal of components containing unknown fluids. Hypro requests this in order to protect the environment and personnel from the hazards of handling unknown fluids.

Be prepared to give Hypro full details of the problem, including the model number, date of purchase, and from whom you purchased your product. Hypro may request additional information, and may require a sketch to illustrate the problem.

Contact Hypro Service Department at 800-468-3428 to receive a Return Merchandise Authorization number (RMA#). Returns are to be shipped with the RMA number clearly marked on the outside of the package. Hypro shall not be liable for freight damage incurred during shipping. Please package all returns carefully. All products returned for warranty work should be sent **shipping charges prepaid** to: HYPRO/PENTAIR - Attention: Service Department - 375 Fifth Avenue NW - New Brighton, MN 55112.

For technical or application assistance, call the **Hypro Technical/Application number: 800-445-8360**, or send an email to: technical@hypropumps.com. To obtain service or warranty assistance, call the Hypro Service and Warranty number: 800-468-3428; or send a fax to the Hypro Service and Warranty FAX: 651-766-6618.

*Carriers, including U.S.P.S., airlines, UPS, ground freight, etc., require specific identification of any hazardous material being shipped. Failure to do so may result in a substantial fine and/or prison term. Check with your shipping company for specific instructions.